

### WIRING METHODS

#### Self-Contained Assembly AXIAL WIRING

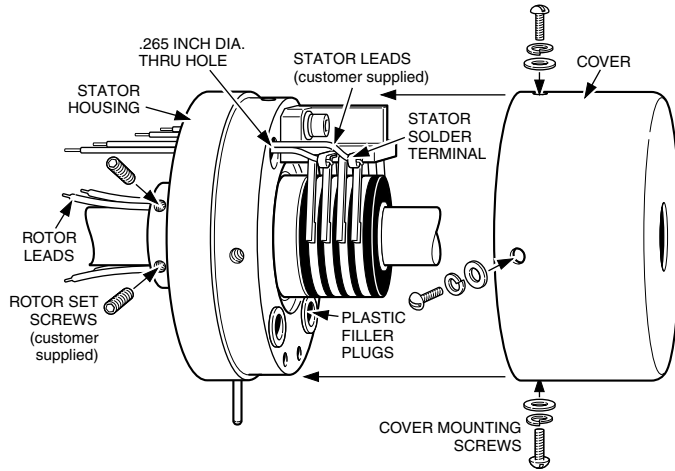

1. Remove cover.
2. Remove plastic filler plugs as required.
3. Insert stator leads through .265 inch diameter hole(s).
4. Solder stator leads to stator solder terminals.
5. Reinstall cover.

#### Self-Contained Assembly RADIAL WIRING

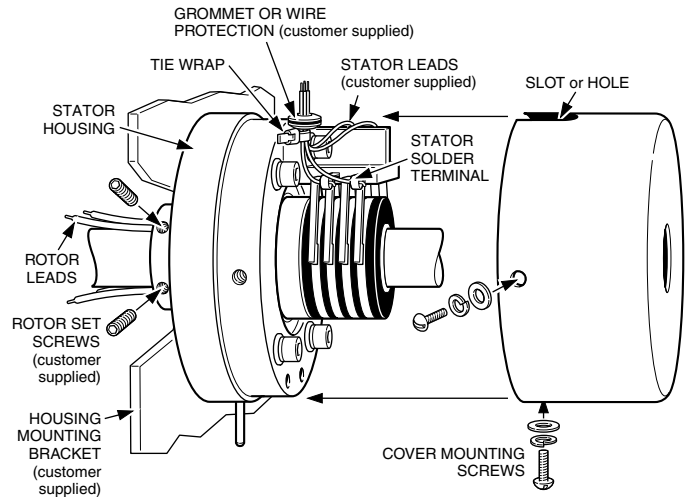

1. Remove cover and machine slot or hole for stator leads.
2. Solder stator leads to stator solder terminals.
3. Tie stator leads together with tie wrap.
4. Stator leads can be secured to slip ring by utilizing one of the brush block mounting bolts to attach a restraining bracket.
5. Reinstall cover.

### RPM RANGE

Fabricast BEST COST & DELIVERY slip rings provide a reliable method of transmitting power and data, from a stationary to a rotating component, with consistently low electrical noise over a wide range of operating speeds. Fabricast BEST COST & DELIVERY slip rings work very well while stationary or rotating either in a single direction or bi-directionally.

Fabricast slip rings, utilizing solid coin silver rings and silver graphite brushes, work well at high speeds of rotation. In general, the maximum RPM for Fabricast BEST COST & DELIVERY slip rings is defined by the maximum surface feet per minute the brush contact material can travel. See Fabricast Catalog page 14, for different brush contact materials and respective maximum surface feet per minute ratings.

Use the following formula to calculate surface feet per minute:

$$\text{Surface Feet Per Minute} = \frac{(\text{Ring Diameter in Inches} \times 3.141 \times \text{RPM})}{12}$$

Please note that this is only a guideline. Maximum operating speeds may be limited by noise (dynamic resistance) requirements, brush life requirements, bearings, and various environmental conditions. For high speed applications please contact Fabricast for help in selecting the appropriate brush material, bearings, and number of brushes per ring to best meet the mechanical, electrical, and environmental specifications of your application.

### OPERATING ENVIRONMENT

Fabricast BEST COST & DELIVERY slip rings can operate in temperatures from -65°F to 250°F. Please note that this is only a guideline. Operating temperature range can be reduced by high RPM and high current specifications.

Fabricast BEST COST & DELIVERY slip rings can be modified to operate in high altitude, dry nitrogen and hard vacuum environments.

**Fabricast, Inc.**® MANUFACTURER OF  
SLIP RING ASSEMBLIES

TELEPHONE: (626) 443-3247  
FAX: (626) 443-5594  
E-MAIL: info@fabricast.com  
WEB SITE: www.fabricast.com