

BEST COST • 2.004 INCH BORE • STOCK DELIVERY

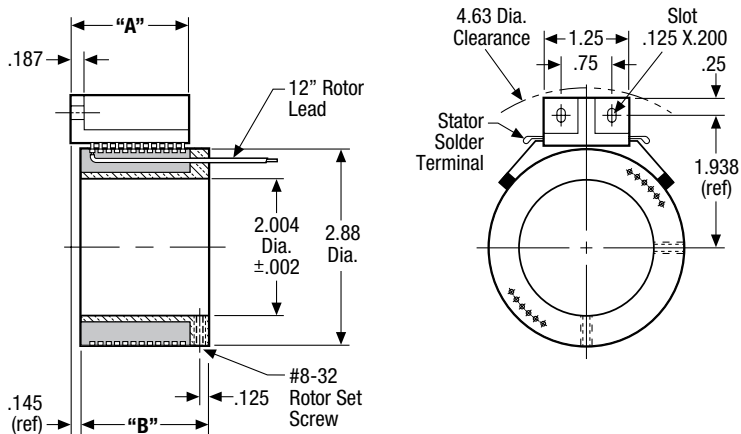

TYPE	No. of Rings	Length "A" Inches	Length "B" Inches
1922	2	.75	.90
1923	3		
1924	4	.99	1.14
1926	6	1.23	1.38
1928	8	1.47	1.62
19210	10	1.71	1.86
19212	12		

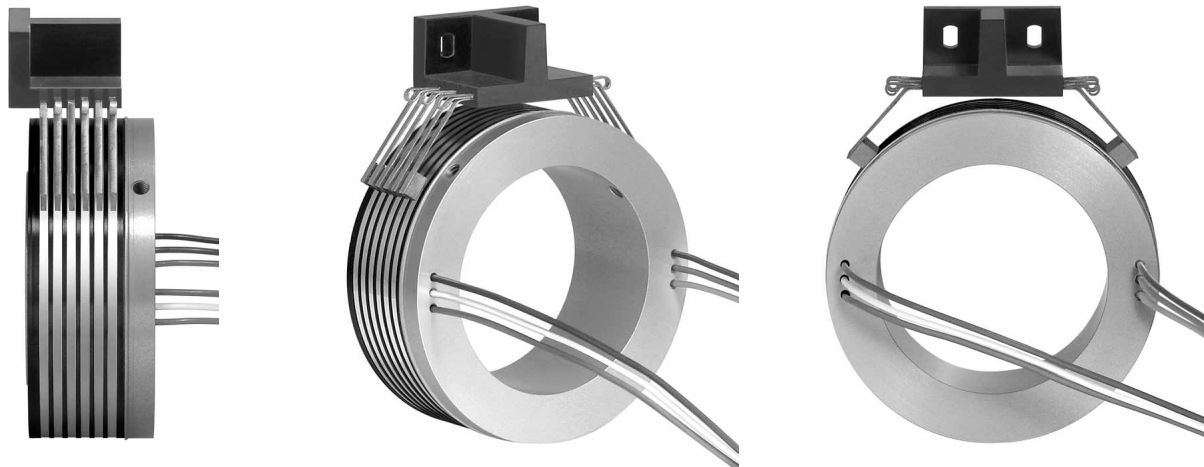

TYPE 1926

P/N 1926-2BR-FAG180 pictured.

CHARACTERISTICS

CURRENT: • 5 amp standard.
• 10 amp optional.

RINGS: • Solid Coin Silver Rings.

BRUSHES: • Silver Graphite.
• Fabricast Grade FAG 180 (80% Ag – 20% C).
• 5 amp capacity with 2 brushes per ring (1 brush block).
• 10 amp capacity with 4 brushes per ring (2 brush blocks).
• Brush complement molded as unit with diallyl phthalate dielectric.

NOISE: • 10 Milliohms maximum dynamic resistance with 2 brushes per ring.
• 5 Milliohms maximum dynamic resistance with 4 brushes per ring.

HI-POT: • 1000 VAC for 15 seconds.

ROTOR: • One piece aluminum sleeve.
• Ring complement molded as unit with diallyl phthalate dielectric.

ROTOR LEADS: • 5 amp leads – 20 AWG per MIL-W-16878 Type "E".
• 10 amp leads – 16 AWG per MIL-W-16878 Type "E".

OPTIONS: • 10 amp current carrying capacity.

- Hard vacuum compatible.
- Consult Fabricast for all available options.
- * Consult Fabricast for optional brush grades and characteristics (see page 14).

COMPLETE ASSEMBLY PART NUMBER CODING – Specify fully when ordering:

Type	Number of Brushes per Ring	Brush Grade Number	Options (If Applicable)
X	X	X	X
	(2BR or 4BR)	*(FAG180)	(10 amp, Vacuum, etc.)

For additional ordering information see page 11.

For Mounting and Wiring Methods, RPM Range, and Operating Environment see pages 9 & 10.

Fabricast, Inc.® MANUFACTURER OF SLIP RING ASSEMBLIES

TELEPHONE: (626) 443-3247
FAX: (626) 443-5594
E-MAIL: info@fabricast.com
WEB SITE: www.fabricast.com