

BEST COST • 1.504 INCH BORE • STOCK DELIVERY

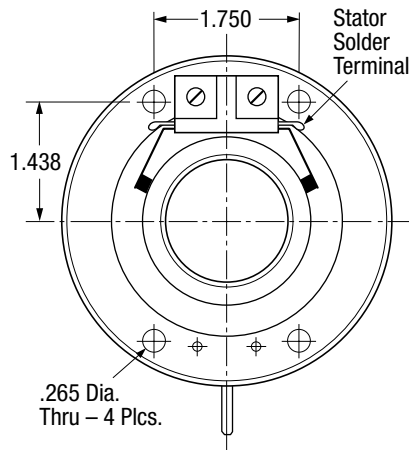

TYPE	No. of Rings	Length "A" Inches	Length "B" Inches
2982	2	1.48	1.56
2983	3		
2984	4		
2986	6	1.72	1.81
2988	8	1.96	2.06
29810	10	2.20	2.31
29812	12	2.44	2.56
29814	14	2.68	2.81
29816	16	2.92	3.00
29820	20	3.40	3.50
29824	24	3.88	4.00

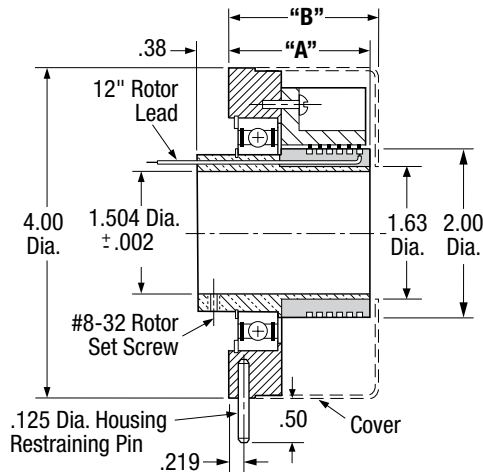

TYPE 2984

P/N 2984-2BR-FAG180 pictured with and without cover.



TYPE 2986

P/N 2986-2BR-FAG180 pictured with and without cover.

CHARACTERISTICS

CURRENT: • 5 amp standard.
• 10 amp optional.

RINGS: • Solid Coin Silver Rings.

BRUSHES: • Silver Graphite.
• Fabricast Grade FAG 180 (80% Ag – 20% C).
• 5 amp capacity with 2 brushes per ring (1 brush block).
• 10 amp capacity with 4 brushes per ring (2 brush blocks).
• Brush complement molded as unit with diallyl phthalate dielectric.

NOISE: • 10 Milliohms maximum dynamic resistance with 2 brushes per ring.
• 5 Milliohms maximum dynamic resistance with 4 brushes per ring.

HI-POT: • 1000 VAC for 15 seconds.

ROTOR: • One piece aluminum sleeve.
• Ring complement molded as unit with diallyl phthalate dielectric.

ROTOR LEADS: • 5 amp leads – 20 AWG per MIL-W-16878 Type "E".
• 10 amp leads – 16 AWG per MIL-W-16878 Type "E".

HOUSING: • One piece aluminum structure.

COVER: • Aluminum.

OPTIONS: • 10 amp current carrying capacity.
• Hard vacuum compatible.
• Consult Fabricast for all available options.
* Consult Fabricast for optional brush grades and characteristics (see page 14).

COMPLETE ASSEMBLY PART NUMBER CODING – Specify fully when ordering:

Type	Number of Brushes per Ring	Brush Grade Number	Options (If Applicable)
X	X (2BR or 4BR)	X *(FAG180)	X (10 amp, Vacuum, etc.)

For additional ordering information see page 11.

For Mounting and Wiring Methods, RPM Range, and Operating Environment see pages 9 & 10.

Fabricast, Inc.® MANUFACTURER OF
SLIP RING ASSEMBLIES

TELEPHONE: (626) 443-3247
FAX: (626) 443-5594
E-MAIL: info@fabricast.com
WEB SITE: www.fabricast.com